

Screw Tip Valves

We manufacture a wide range of valves to meet the needs of today's injection molders.



We are a leading manufacturer of non-return screw tip valves; utilizing the most advanced technology in both the design and manufacturing process, combined with years of experience to produce top quality valves.

- High quality materials
- Coating and treatments
- Unsurpassed workmanship
- Attention to detail
- Providing a product of unsurpassed value to our customers.

Screw Tip Function

The screw tip valve is one of the key components in the molding process. The ever-widening range of both materials and processes faced by injection molders, along with the need for increased quality and productivity, makes screw tip valve function even more of a critical concern.

The feed screw rotation moves and melts material that must then flow through the screw tip valve building up forward pressure that forces the screw

back. The accumulated plastic in front of the valve is then injected into the mold, keeping material from escaping back onto the feed screw, which is the function of the screw tip or non-return valve.

Poor valve function results in inconsistencies and inefficiency in the molding process. There are many design and process considerations for proper valve function that should be considered.

FULL BACK VIEW

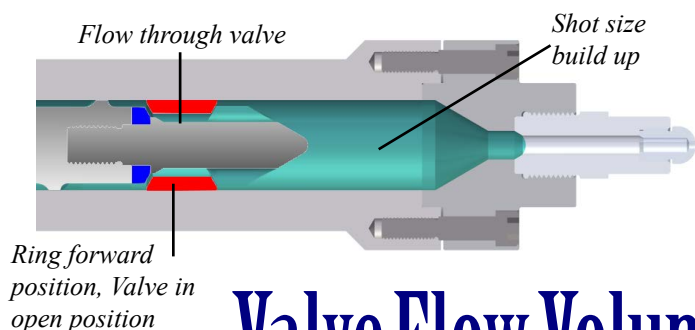

Ring back, Valve in closed position

FULL FORWARD VIEW

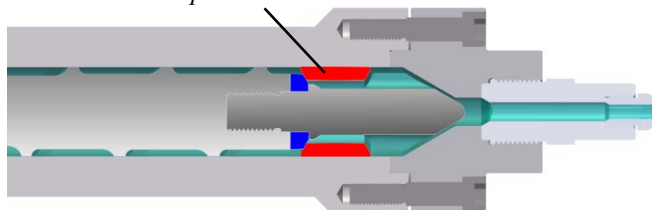

Valve Flow Volume and Pressure Drop

The key element in a screw tip valve is the flow volume through the valve. Higher flow volumes are generally referred to as Free Flow Designs; many ball check and some hybrid 3 and 4-piece construction designs offer very limited flow areas. Flow volumes are both a function of mechanical limitations and functionality needs. Common designs generally have flow volumes that range from 35 to 75% of the cross section of the feed screws exit or meter area.

The flow volume of a screw tip valve is determined by the smallest area of volume available in the unit. On standard ring type valves, this

is generally the area of flow between the main body of the stud and the inside diameter of the ring, or by the distance of movement (travel) of the check ring.

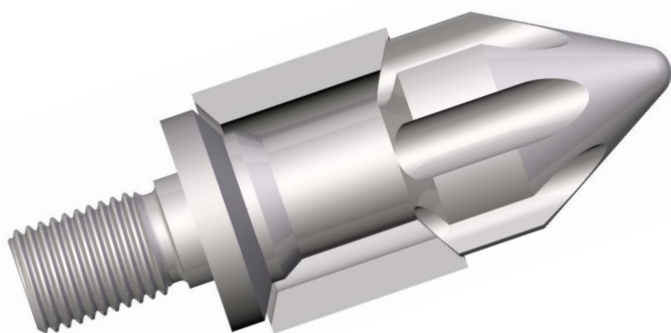
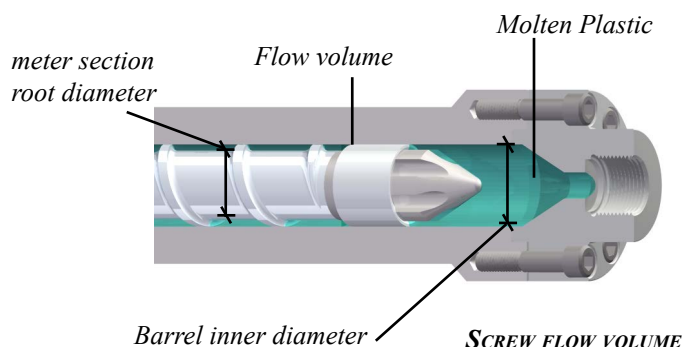

The more restrictive the flow requires the screw to build higher pressures and moves the areas of pressure buildup further back on the screw's length. This can be beneficial for some applications and materials that require greater energy for mixing action and present problems for other materials that are sensitive to shear or pressure energy.

Valve Types

There are three main valve designs distinguished by the valve's contact with the barrel surface:

Floating & Open Rotation Check Rings: this is any valve with a free floating ring that is not locked to the screw rotation. These are most commonly 3-piece or 4-piece design valves.

The ring rotates only to the degree of drag-force created during screw rotation from contact on the forward face to the valve body face (stud). The largest abrasion is on these surfaces and generally the impact of the wear of these surfaces dictates the useful life of the valve. The abrasion impact on the ring's outside diameter is less, as ring rotation is generally below 1/3 of the screws speed.

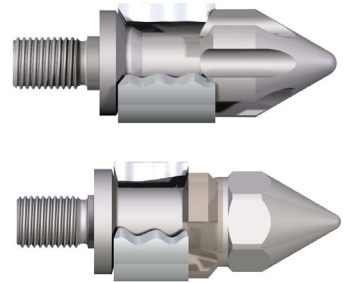

Floating & Fixed Rotation Check Rings: these valves have check rings with feet or pins that lock the ring into the rotation of the feed screw, often referred to as "locking check rings". The ring still has lateral freedom of movement.

These designs generally offer improved shot control over open rotation rings. There is little wear on the ring or screw tip stud face. The abrasion is transferred from the faces to the outer diameter of the check ring and it is this wear surface that dictates the useful life of the valve.

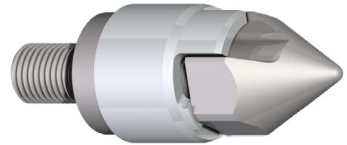

Completely Fixed Valves: these are generally considered ball-check valves. The entire valve is fixed to the feed screw flow through channels on the inside of the valve with a ball or pin to control flow. Be sure to check out our Sure-Shot.

These designs offer the best consistency for shot control; however, many designs offer very limited flow volumes and can be difficult to purge. Having a fixed rotation with the screw, the largest wear impact is on the outside diameter. General wear of this outside surface dictates the useful life of the valve.

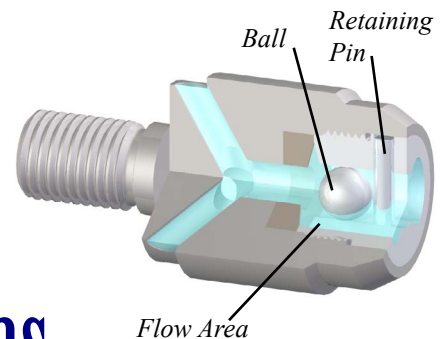

Mechanical Limitations

Injection molding valves are subject to extreme forces of temperature, pressure, torsion, abrasion and impact. These forces impact different design valves in various ways, based on factors like injection pressure, screw speed and the materials processed.

The most common force concern of molders tends to be the abrasion and wear generated from it.

Over-compensating for abrasive concerns with harder, more wear-resistant steels, can produce a valve with little ability to withstand torsional or pressure forces.

There have been many new, innovative materials, treatments and coatings used for screw tip valves. Our expertise in design can provide the best value for your screw tip valve needs.

P - 700

GENERAL PURPOSE

3-Piece Free Flowing Design



Designed with generous flow volumes and direct flowing, highly polished flow paths, this valve provides very little pressure drop; providing fast screw recovery rates, easy and fast purging for material and color changes.

The P-700 design leaves very little dead space forward of the feed screw for maximum displacement of the polymer.

Wear Resistance



Flow Volume

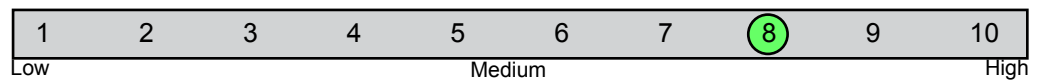

Shear Impact







Torsional Strength

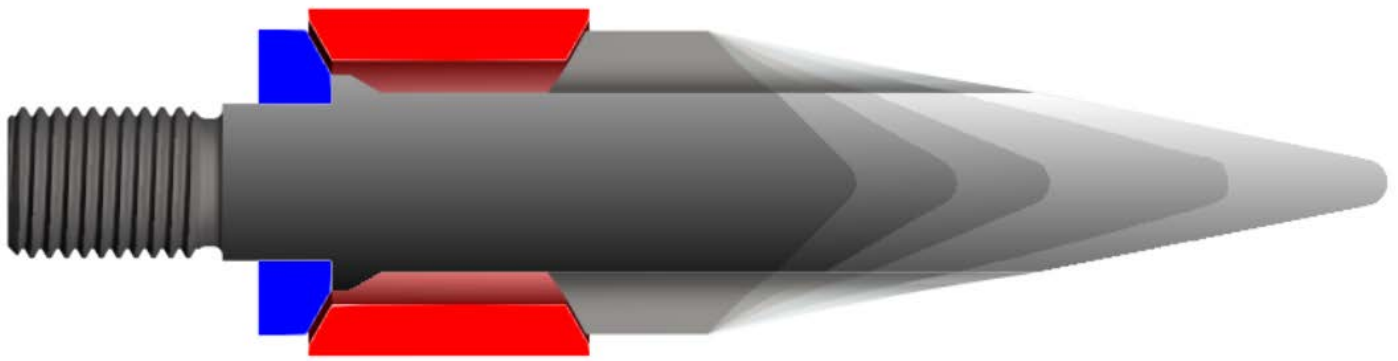

Purging





-  Stud/Retainer
-  Check Ring
-  Rear Seat

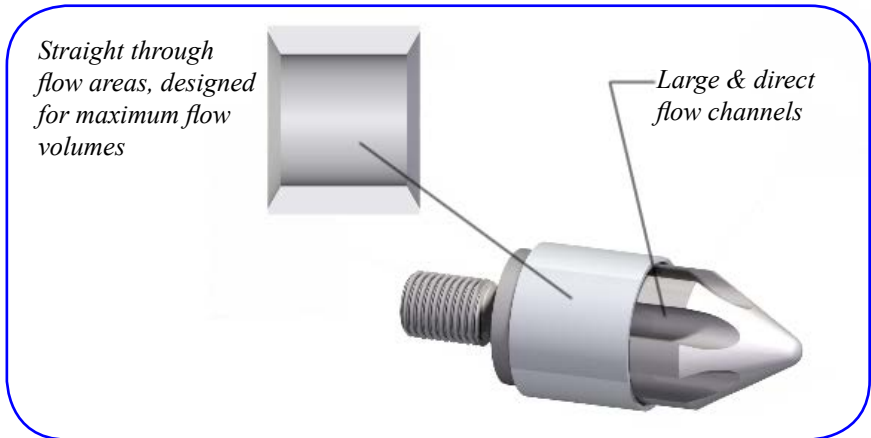

Materials

All three components of the P-700 screw tip are manufactured from H-13 tool steel that is heat-treated to the maximum safe Rockwell hardness, based on the valve geometry that will range from 52 to 59. The components are Ion Nitride surface hardened for added wear protection. Nitride provides a case hardness of up to 70 Rockwell with a case depth up to .015" per side.

Recommended Applications

Recommended for use on shear or compression sensitive materials, general purpose materials and "limited run time" filled materials.

Use on highly fiber filled materials will maintain fiber integrity and result in higher tensile strengths in the molded part; however, faster wear of the valve may be experienced.

Limitations

The P-700 design may not perform well on applications requiring high or moderate screw speeds or that utilize greater than 75% of the injection capacity. The abrasive action of the ring-to-stud contact at fast or prolonged use will generate heat that may anneal the hardness of the tool steel.

Applications using moderate to low viscosity polymer may experience shot control (cushion) problems. The higher flow volumes of this design may allow these polymers to escape before a solid seal is created and cause an imbalance of pressures.

P - 770 SPIN-LOCK

General Purpose 3-Piece Inter-Locking Ring



Designed with generous flow volumes and direct, highly polished flow paths, this valve provides very little pressure drop. Providing fast screw recovery rates, it's easy and fast purging for material and color changes.

The P-770 Spin-Lock design leaves very little dead space forward of the feed screw for maximum displacement of the polymer.

Wear Resistance



Flow Volume

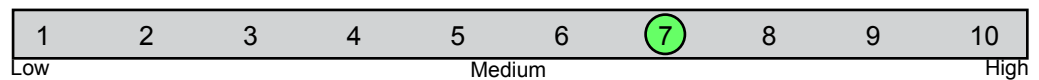

Shear Impact





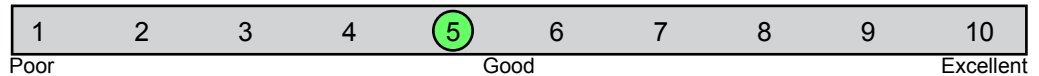

Torsional Strength

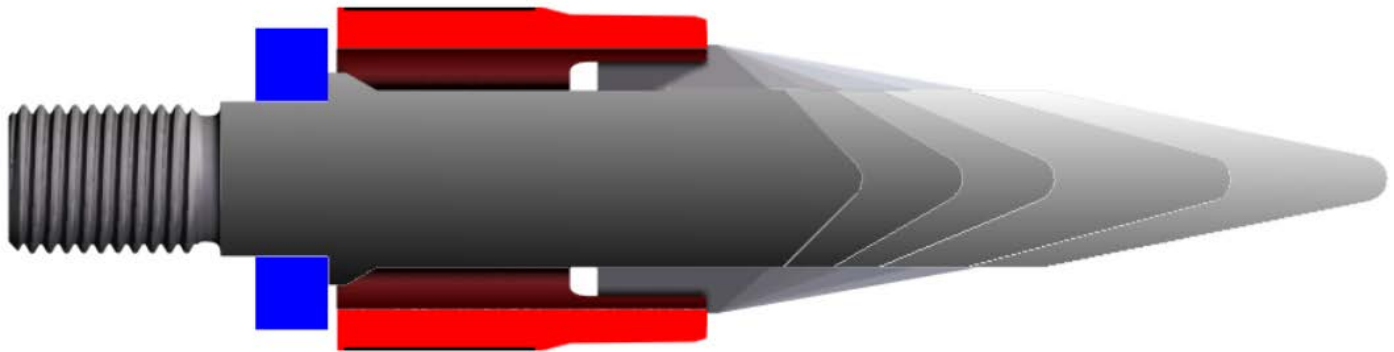

Purging





-  Stud/Retainer
-  Check Ring
-  Rear Seat

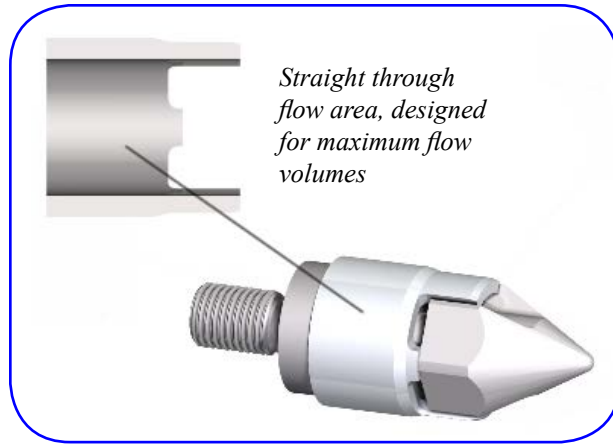

Materials

All three components of the P-770 Spin-Lock screw tip are manufactured from H-13 tool steel that is heat-treated to the maximum safe Rockwell hardness, based on the valve geometry that will range from 52 to 59. The components are Ion Nitride surface hardened for added wear protection. Nitride provides a case hardness of up to 70 Rockwell with a case depth of up to .015" per side.

Recommended Applications

The P-770 performs well on shear or compression sensitive materials as well as general purpose materials and material with moderate fill percentages. It performs well at high screw speeds and when a large percentage of shot size is utilized.

Limitations

This product may not perform well on applications using very high viscosity polymers or materials with greater than 15% fillers. Care should be used on start-up to ensure polymer is molten, as the interlocking check ring design is more susceptible to damage than other designs.

C-770

CARBIDE SPIN-LOCK

High Wear, 3-Piece Inter-Locking Ring

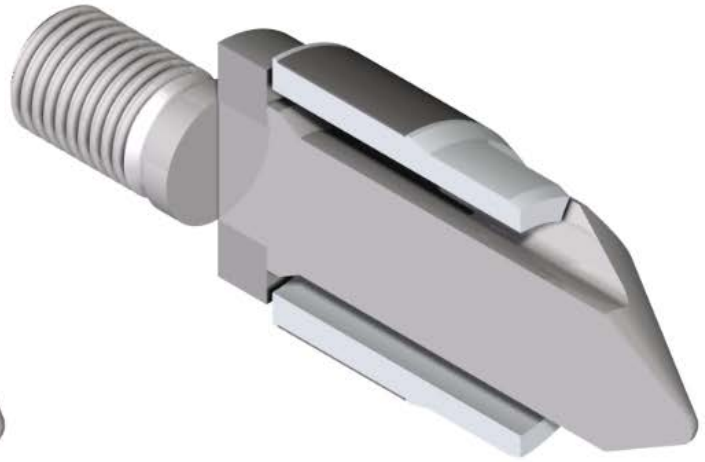

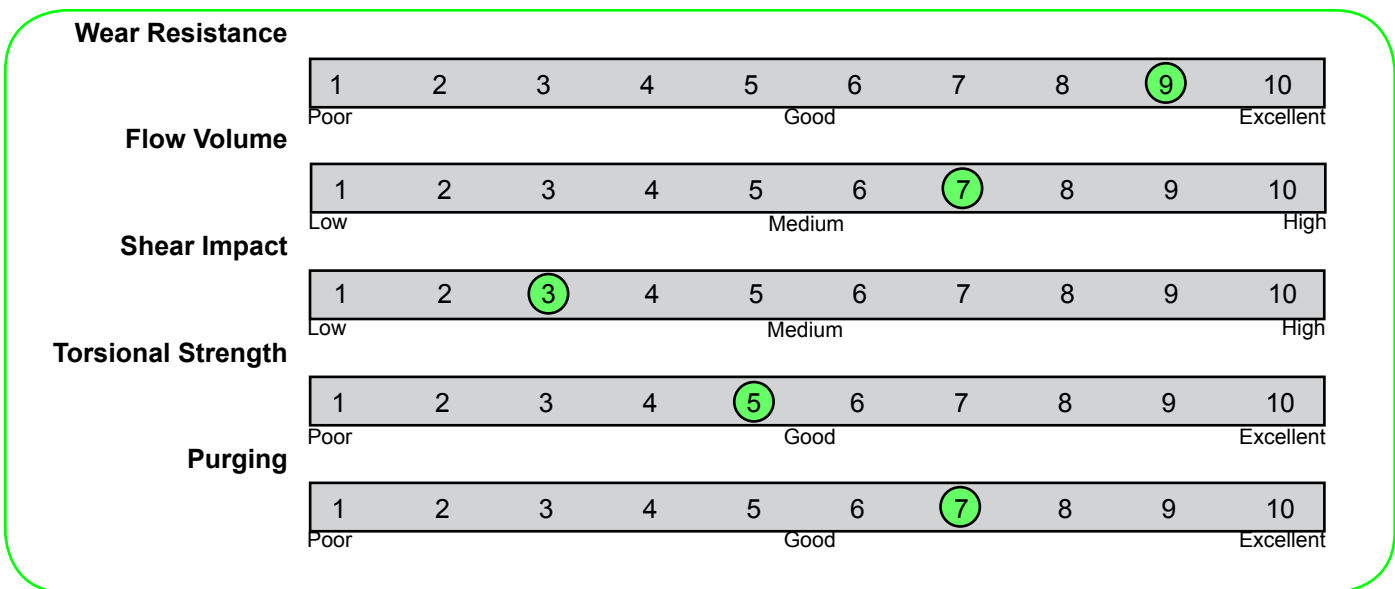

Our carbide spin-lock screw tip is manufactured with an ultra high abrasion resistant 88% Tungsten Carbide inlay on the check ring outer diameter providing extended service life. Designed with generous flow volumes, direct, and highly polished flow paths. This valve provides very little pressure drop, providing fast screw recovery rates, it's easy and fast purging for material and color changes.

Our C-770 Spin-Lock design leaves very little dead space forward of the feed screw for maximum displacement of the polymer. This design has excellent shut-off characteristics as well.

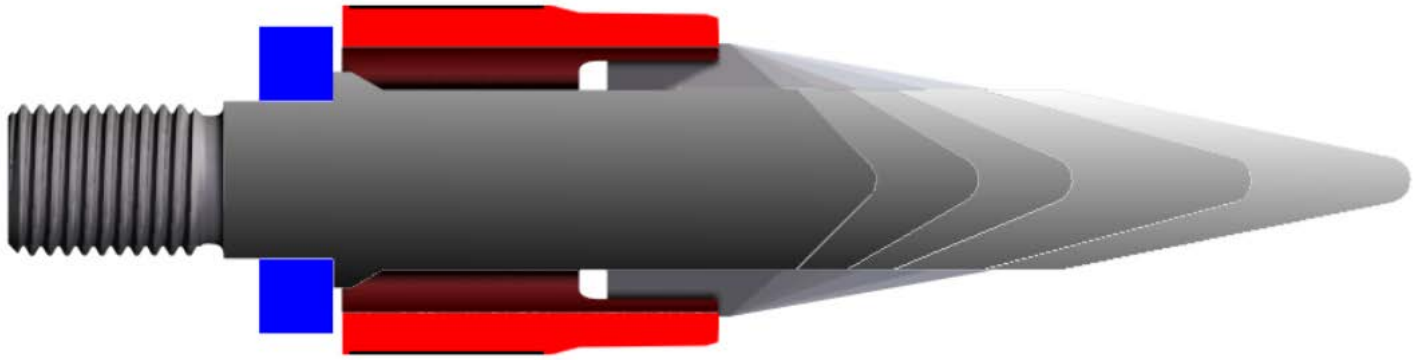



-  Stud/Retainer
-  Check Ring
-  Rear Seat

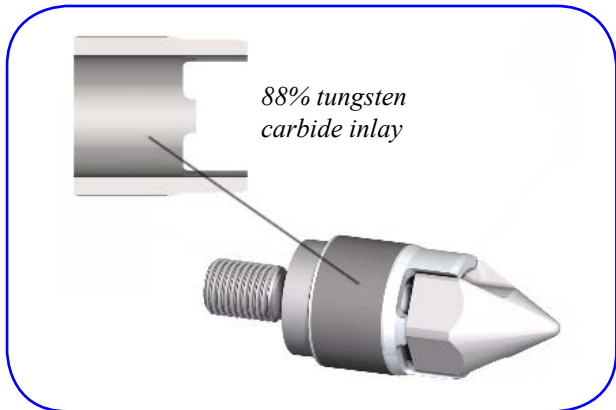

Materials

The screw tip (stud) and rear seat are manufactured from H-13 tool steel that is heat-treated to the maximum safe Rockwell hardness, based on the valve geometry that will range from 52 to 59. The components are Ion Nitride, surface hardened for added wear protection. Nitride provides a case hardness of up to 70 Rockwell with a case depth of up to .015" per side.

The check ring is manufactured from the same materials with the added benefit of inlaid Tungsten Carbide on the outer diameter, applied .010" - .011" thick per side to provide total wear protection of .020" - .022".

Recommended Applications

The C-770 performs well on shear or compression sensitive materials as well as general purpose materials and material with moderate fill percentages. It performs well at very high screw speeds and when a large percentage of the shot size is utilized.

Limitations

This product may not perform well on applications using very high viscosity polymers or materials with greater than 15% fillers. Care should be used on start-up to ensure polymer is molten, as the interlocking check ring design is more susceptible to damage than other designs.

P - 2000S

HIGH ABRASION - HIGH FLOW

4-Piece Construction



The design offers excellent wear resistance on the main replaceable wear components – the ring, wear seat and rear seat. These are combined with an extremely high tensile strength retainer (stud) to withstand shock or rigors of improper starting.

The geometry of the wear seat using three large high flow material paths, cut at gentle angles that blend into the retainer, provide greater and more streamlined flow than similar 4-piece designs. The check ring's straight-through design improves the flow volumes and creates less pressure drop. This allows for a faster screw recovery even with high viscosity or highly filled polymers.

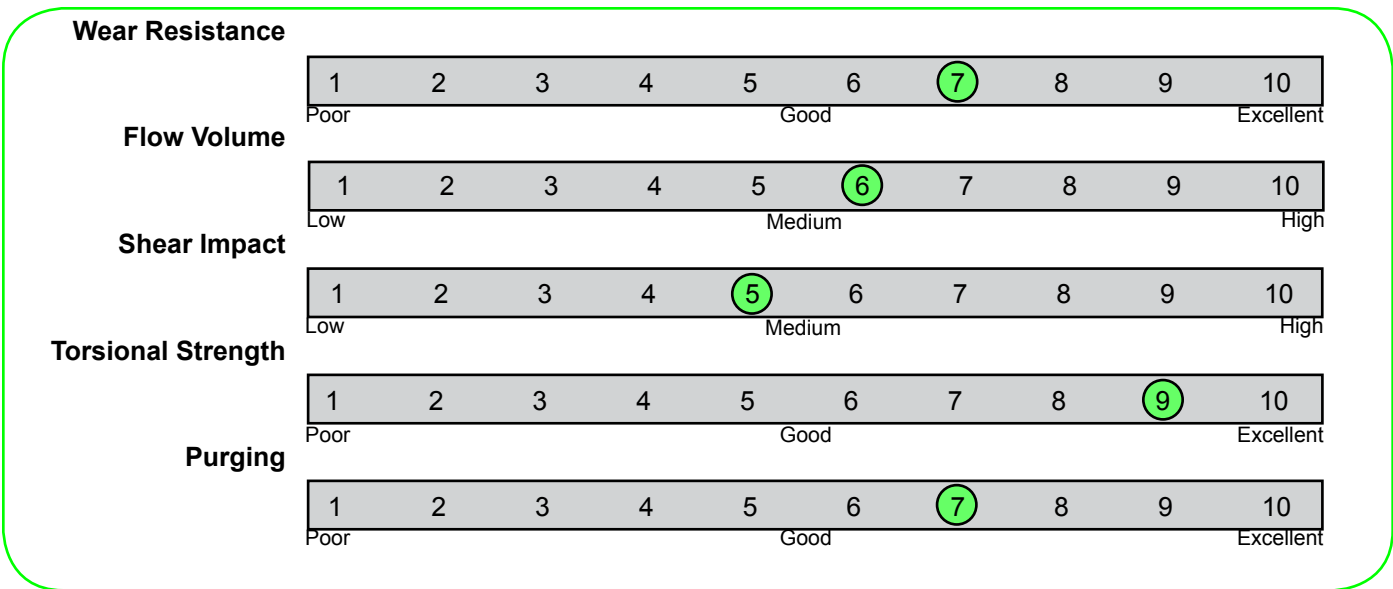

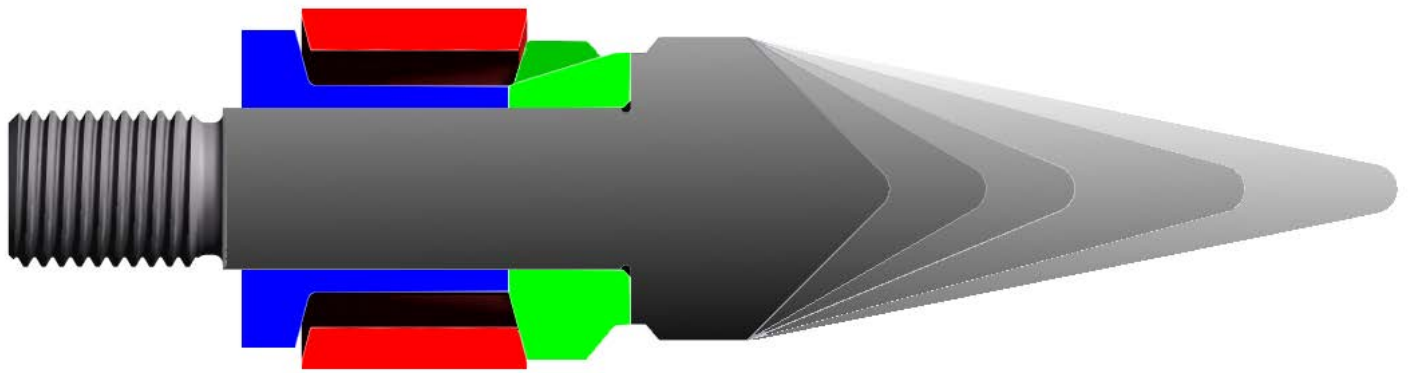

- Stud/Retainer
- Check Ring
- Rear Seat
- Wear Seat

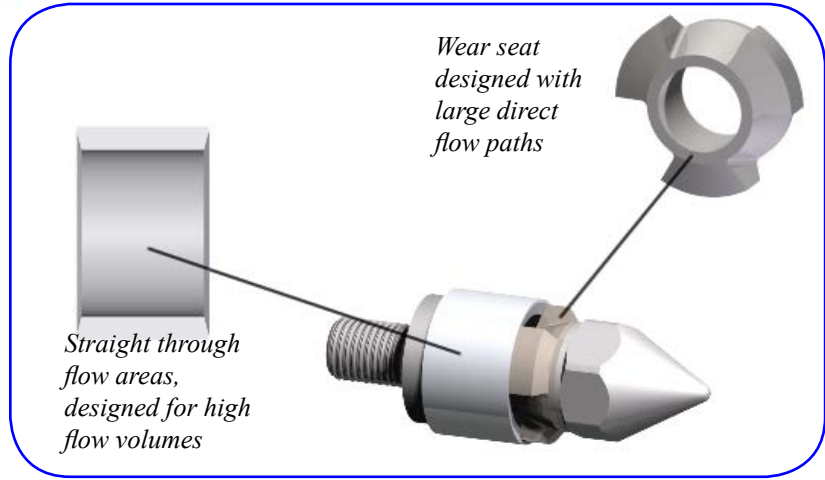

Materials

The key wear components are manufactured from high quality tool steels containing very high levels of the carbide forming element Vanadium which is one of the hardest and most wear resistant carbides.

The retainer (stud) is manufactured from 17-4PH stainless steel and is standard on ring sizes of 2.50" (65mm) or less and optionally offered on larger sizes. Larger sizes are manufactured from pre-heat-treated 4150 alloy steel. These materials have tensile strengths greater than 185,000 PSI, which is up to two times greater than materials commonly used on 3-piece design valves. This provides excellent torsional strength to absorb twisting and bending forces that can cause stud breakage.

Recommended Applications

This design provides real value for larger size machines and applications using very high viscosity polymers or materials with very high levels of fillers. Long fiber materials will benefit from the gentle and generous flow paths, resulting in less fiber damage and a stronger molded parts.

Limitations

This design will not perform well with low viscosity polymers in terms of cushion or shot control. Also, it may not perform well on applications requiring high or moderate screw speeds or that utilize greater than 75% of the injection capacity. The abrasive action of the ring-to-wear seat contact at fast or prolonged use will generate heat that may anneal the hardness of the tool steel.

P - 2000R

HIGH ABRASION

4-Piece Construction



This design offers excellent wear resistance on the main replaceable wear components – the ring, wear seat and rear seat. These are combined with an extremely high tensile strength retainer (stud) to withstand shock or rigors of improper starting.

The geometry of the wear seat, using three large high flow material paths cut at gentle angles which blend into the retainer, provides greater and more streamlined flow than similar 4-piece designs. The check ring's reversing internal taper design improves shot control by creating resistance to back flow and capturing added pressure forward of the valve.

Wear Resistance



Flow Volume



Shear Impact



Torsional Strength



Purging



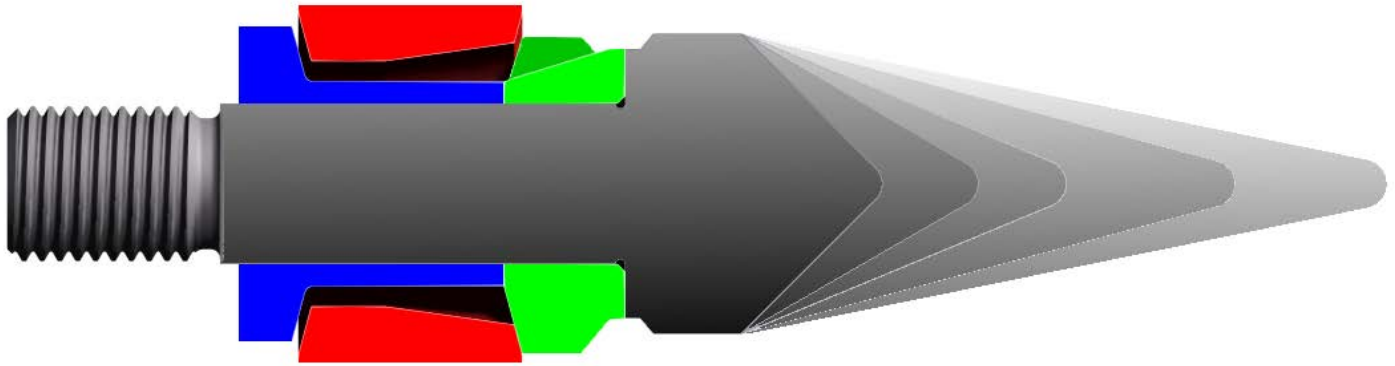

- Stud/Retainer
- Check Ring
- Rear Seat
- Wear Seat

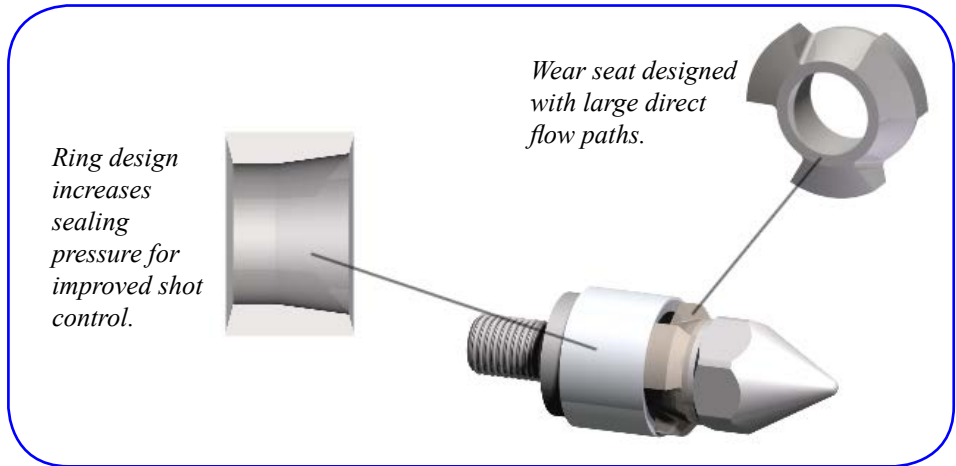

Materials

The key wear components are manufactured from high quality tool steels containing very high levels of the carbide forming element, Vanadium, which is one of the hardest and most wear resistant carbides.

The retainer (stud) is manufactured from 17-4PH stainless steel and is standard on ring sizes of 2.50" (65mm) or less and optionally offered on larger sizes. Larger sizes are manufactured from pre-heat-treated 4150 alloy steel. These materials have tensile strengths greater than 185,000 PSI, which is up to two times greater than materials commonly used on 3-piece design valves. This provides excellent torsional strength to absorb twisting and bending forces that can cause stud breakage.

Recommended Applications

This design provides real value for larger size machines and applications using very low viscosity polymers, which will benefit from improved shot control.

Limitations

This design will not perform well with very high viscosity polymers in terms of flow. It also may not perform well on applications requiring high to moderate screw speeds, or utilize greater than 75% of the injection capacity. The abrasive action of the ring-to-wear seat contact at fast or prolonged use will generate heat that may anneal the hardness of the tool steel.

Injection Molding Just Got a Whole Lot Easier!

SURE-SHOT

The **SURE-SHOT** screw tip offers the best in class performance to meet the needs of today's most challenging molding applications. Offering quick, precise and consistent shot control. **SURE-SHOT** makes it very easy to process any polymer regardless of its viscosity.

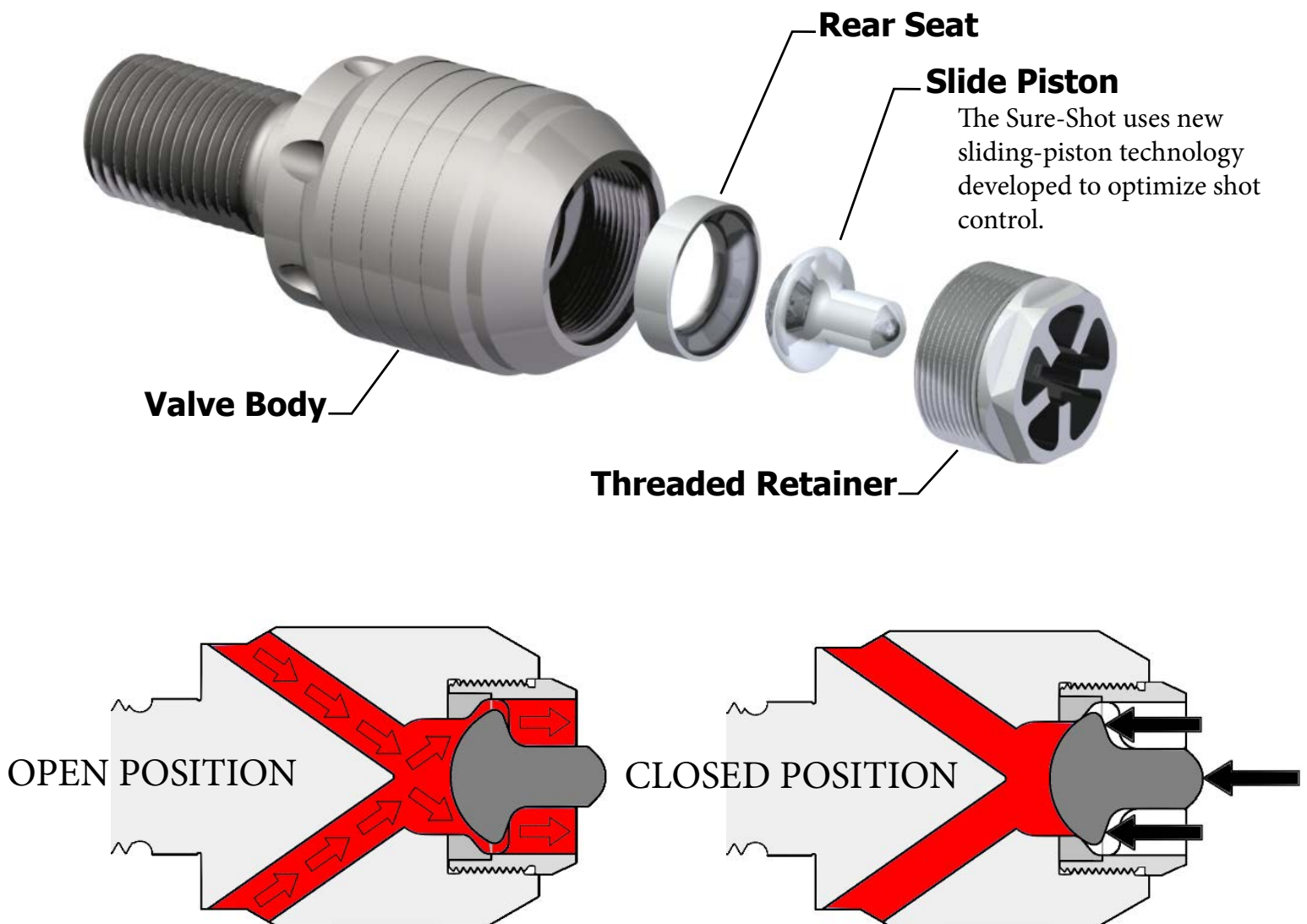

Shot Control- Shut-off is controlled by a sliding-piston which is designed to react instantly as the screw moves forward sealing back-flow. The design causes the pressure behind the piston to decrease and the pressure in front of it to increase as the screw begins to move forward creating a fast acting and positive shutoff.

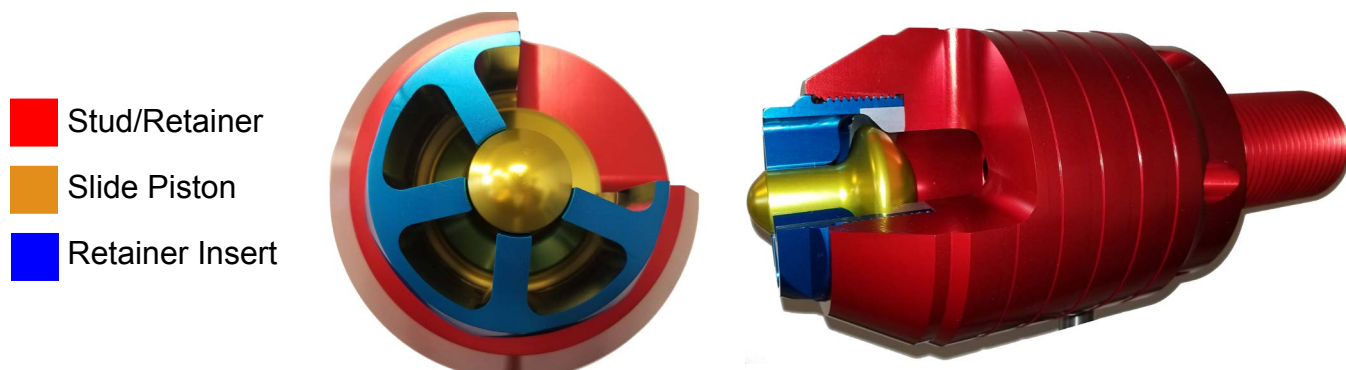

Flow Volume- The Sure Shot non-return valve is the first of its kind developed with flow dynamics that provide little or no pressure drop thru the valve greatly reducing shear in the polymer. This also allows for faster recovery times.

High Screw Speeds- Unlike floating ring valves the Sure Shot is suitable for high screw speed applications. The valve body has been designed to minimize surface contact area with the barrel to reduce heat build-up and galling.

Construction- Designed with removable wear components and manufactured from high quality tool steels the Sure Shot offers both the necessary strength and durability for long term operation. The main body can also be supplied with a Tungsten Carbide coating on the outside diameter.

Purging and Color Change- Our flow path design with very steep internal flow angles optimizes direct flow and self-cleaning. Sure Shot features the most flow channels in the industry. This eliminates dead flow zones between the valve and the feed screw. Every Sure Shot is designed with six flow channels allowing the polymer to evenly flow from the feed screw.

Ease of Use- The Sure Shot reduces or eliminates the need for screw decompression sometimes referred to as suck-back.

Sizes- Sure Shot valves are offered in sizes from 50mm up to 260mm. Unlike many suppliers, the Sure Shot has 8 different sliding-piston sizes to maintain high flow volumes across the entire product size range.



CM - 2000

HIGH FLOW BALL CHECK

replaceable insert design

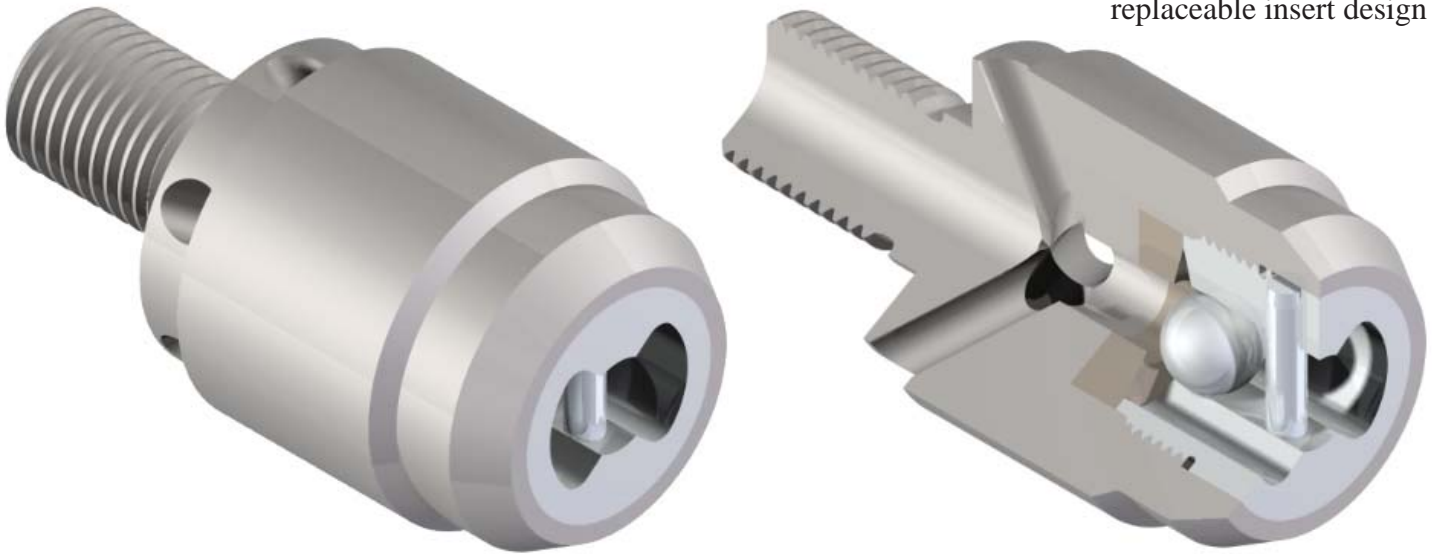



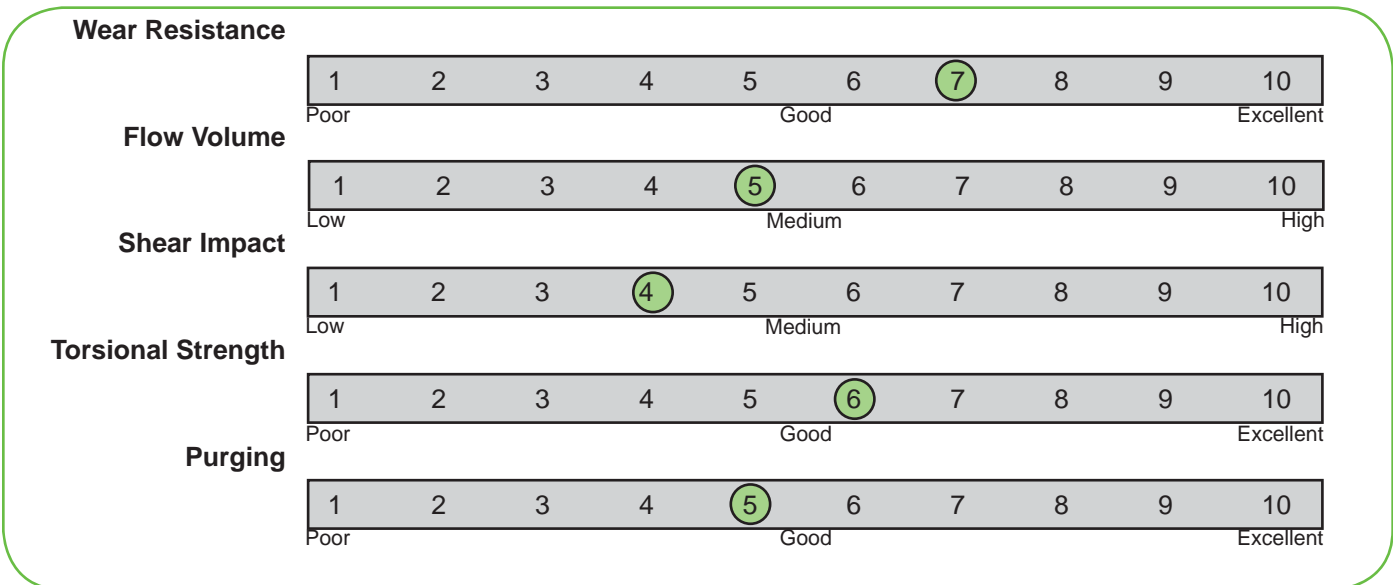

This design provides very high flow volumes compared to other designs, using a concept which supports the ball allowing only lateral movement. This allows the use of larger sealing surfaces as well as flow areas, providing volumes that in many sizes offer similar flow to standard ring valves. The front discharge provides improved flow characteristics

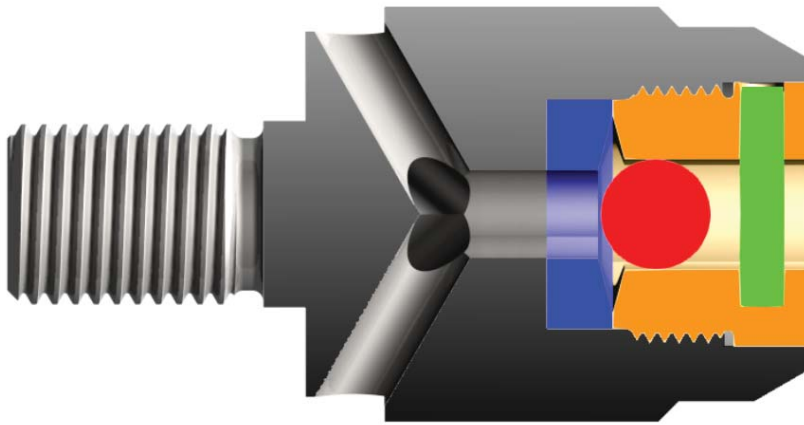
over tip and side flow designs, with replaceable internal wear components for extended use. The CM-2000 can be used in applications where other ball check designs create screw recovery and purging issues.





-  Stud/Retainer
-  Check Ball
-  Rear Seat
-  Retaining Pin
-  Retainer Insert

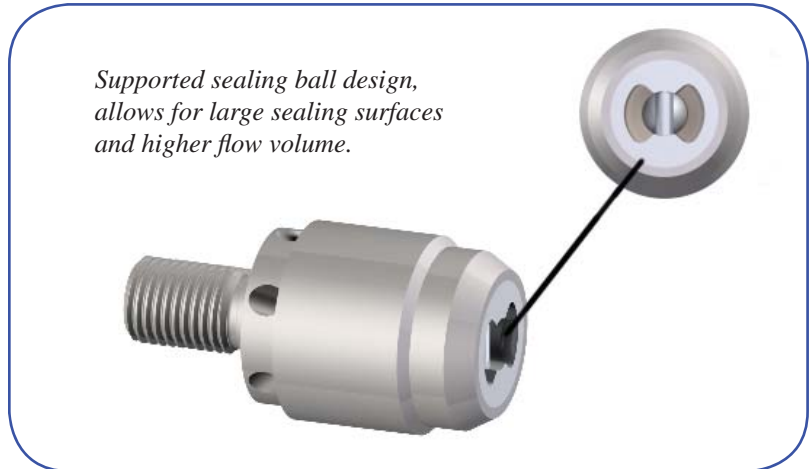

Materials

The main body is manufactured from high quality tool or alloy steel depending on the thread to outer diameter size ratio, both heat-treated and nitride surface hardened for maximum wear resistance and toughness.

The replaceable wear parts are manufactured from high quality tool steels containing very high levels of the carbide forming element Vanadium which is one of the hardest and most wear resistant carbides.

Recommended Applications

The CM-2000 performs well at high screw speeds and when a large percentage of shot size is utilized. It will provide consistent shot control on a very wide range of materials and is often used for difficult very low viscosity applications. Because of its gentle and generous flow paths, materials with low to moderate fill percentages will perform well.

Limitations

High flow volumes cannot be achieved on sizes with outer diameters of less than 2.5" or 65mm. This design will not perform well with very high viscosity or very high fill level polymers.

Custom Screw Tips

We manufacture screw tip valves and supply custom designs, as well as provides valves made from any materials to meet your specifications or process needs.

We have many years of manufacturing with our process knowledge can provide solutions to the most difficult processing problems.



Screw Tip Removal

Removing a screw tip can often be very difficult. Below are some helpful tips:

- A) When possible keep the screw locked into the drive system, this will provide added resistance to counter rotation.
- B) Leave the barrel loaded with material, if necessary, allowing the material to cool and harden will provide added resistance to counter rotation.
- C) Never extend the screws flight area from the barrel or only as much as is necessary. The torsional forces needed to loosen the valve may bend the feed screw.
- D) External heating of the screw can be a very effective tool in removing a tip. Steel expands under heat and may provide the added release needed. The most effective way to utilize the effect of expansion is to create the largest differential in expansion and heat between the female thread in the screw and the male thread of the tip. Allowing the components to cool to ambient then applying gradual to moderate heat very evenly to only the feed screw, is the best way to archive the greatest expansion differential in the parts.
- E) Cutting the screw tip off the feed screw is often done as a last resort; standard operation tightens the threads together creating pressure on the lateral surfaces of the feed screw and screw tip. Cutting the valve in a manner that will release this pressure will often allow the balance of the screw tip thread in the screw to be more easily removed.

Threads

In most injection molding machines the screw rotates in the direction that requires Left Hand threads be employed for the screw tip valve. There are a number of machine manufacturers that employ screws that rotate in the opposite direction using Right Hand threads. This information can be found in your machine's instruction manual.

Whenever a screw tip is replaced the threads on the screw should be inspected for damage, some polymers will produce corrosive gases that will attack both the threads of the valve as well as in the feed screw.

The screw's threads could be cleaned of all degraded polymer and anti-seize compound, this is best done with a Clean-Out Tap. Extended use and high heat can create distortion of the threads that can be addressed in most cases by re-tapping as well. This will make removing the screw tip substantially easier when the time comes.

Proper Orientation

Us and other valve manufacturers offer units that require proper component orientation generally the check ring. Proper orientation can be critical for proper valve function.

Counter Bore and Register Diameter

The counter bore in the face of the feed screw is meant to provide added seal from polymer entering the thread area as well as provide alignment for the screw tip. There should be limited clearance between the OD of the screw tip and the ID of the screw in this area for proper function.

The register diameter is the point on the screws outside diameter where the screw tip valve meets (see drawing below). Many original equipment manufacturers and after market suppliers offer a variety of screw designs that may require different diameters at this point. Contact your machine or screw manufacturer to determine the register size if you are unsure. Miss match in this area can cause materials flow and build up problems.

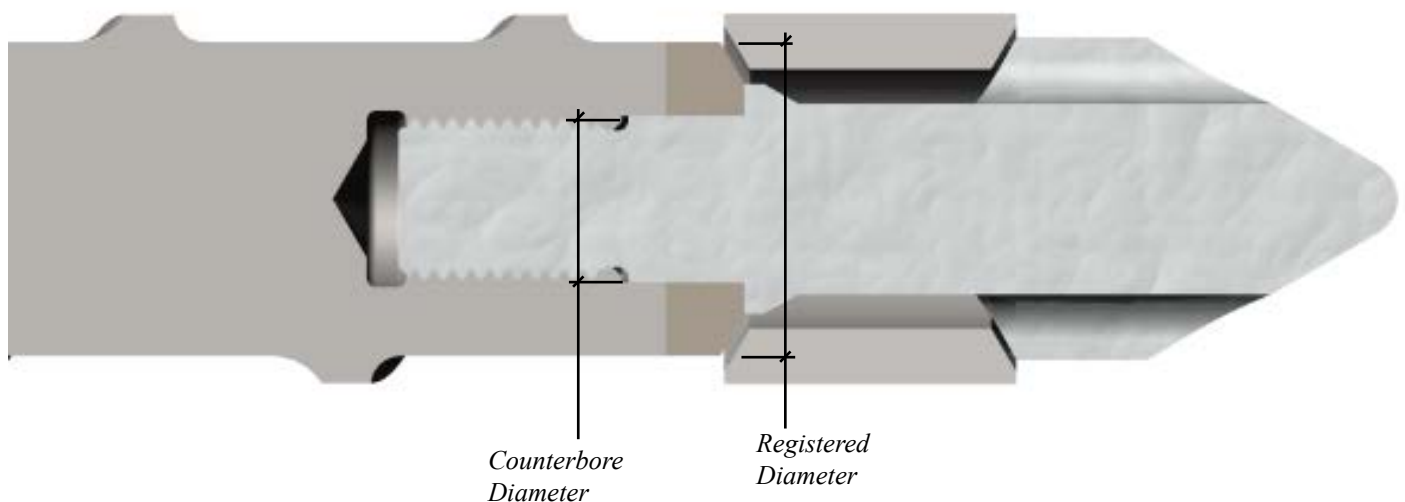

Common Screw Tip Issues

Wear

In most cases, standard or excessive valve wear has little to do with the materials being processed. Most valve wear results from mechanical abrasion and pressures. Material types impact the wear mainly due to the amount of pressure their viscosity creates as it passes through the valve.

Screw speed increases the level of material that passes thru the valve and increases the pressure on the valve. The machine's back pressure creates the same increased pressure effect on the valve. High viscosity and heavily filled materials should be processed using a valve with high flow volume. Shot control is generally not an issue. The lower viscosity materials require more flow restricted flows for proper shot control.



Corrosive Wear

Corrosive wear is often overlooked or mistaken as abrasive wear. Corrosive materials attack the Iron content of the materials used to manufacture valves, often resulting in pitting or groves in the sealing surfaces of the valve. These effects, combined with abrasive wear, can result in premature valve failure.

Even highly corrosive materials have little effect on the valve in normal cycle processing. Exclusive shear and temperature that degrades the polymers create conditions of corrosive wear. These materials should not be allowed to degrade. Purging them with inert materials for shut-down, and start-up will minimize there corrosive effect. If the machine is taken out of cycle for shorter periods of time, reduce the barrel temperatures and purge every few minutes before the materials in the barrel have a chance to degrade.



Breakage

Valve breakage and fractures (cracks) of the components are a common problem. The harder and more wear resistant a material, the lower its tensile strength or resistant and twisting forces. Most valve failures due to breakage, are the result of improperly employed materials. Commonly these failures occur in a short time after installation.

It would be possible to manufacture a valve from material containing 90% Tungsten Carbide; this would provide wear resistance that would allow use for many years. However, due to very brittle nature of this material it would break during installation or shortly thereafter.

Use care in choosing valve materials, balancing the need for wear resistance with the likelihood of breakage. The ring outside diameter and overall size ratio to valve thread size plays a key part in the materials that can be safely used for its construction.

Valves employing harder more wear resistant materials or elements for the key abrasive impact points and softer/stronger materials for the areas of the valve that must withstand the twisting forces, offer the best option for addressing valve longevity.

Breakage can occur for many other reasons, engaging the rotation or lateral movement with un-molten polymers is a common problem that can cause breakage. Many newer machines are equipped with systems that limit movement until the appropriate temperature is reached.



Shot Control or Cushion

Consistent displacement of polymer is mainly the function of the screw tip. Even very small changes in the amount of material displaced creates problems like short shot or flash. These problems are generally due to wear on the valve or barrel inside diameter and, in some cases, higher levels of wear on the feed screw.

All screw tips allow some level of material to escape back thru or into the feed screw. It is the consistency of this level that is important, providing a repeatable process that can be controlled.

The pressure created forward of the valve as the screw pushes forward and the drag of the check ring against the barrel, are the key elements to force sealing of the valve. The higher the resistance to forward flow the more pressure the valve must endure and control during injection.

A screw's forward velocity is the main area of adjustment to control valve performance. Generally the higher the resistant to flow thru the valve the better its shot consistency, and ability to maintain consistency as wear occurs on all of the components.

Presenting our Sure Shot Screw Tip and don't forget to ask about the Extreme Coatings we offer.

Injection Molding Just Got a Whole Lot Easier!

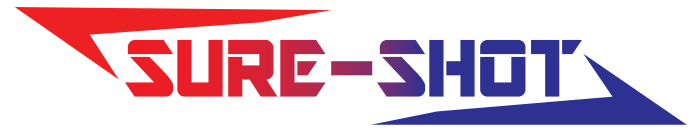

The **SURE-SHOT** screw tip offers the best in class performance to meet the needs of today's most challenging molding applications. Offering quick, precise and consistent shot control. **SURE-SHOT** makes it very easy to process any polymer regardless of its viscosity.

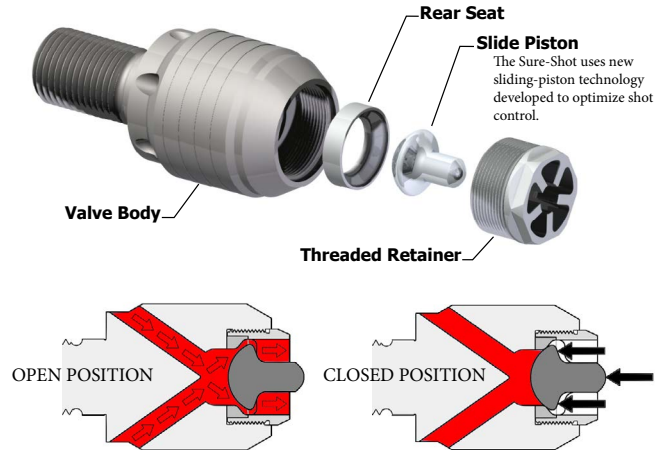

Feedscrews that Last 2X LONGER Superior Performance & Service Life with CARBIDE[®]X

- **Industry:** Plastic & Rubber
- **Application:** Single & Twin Screws, Mixing Rotors
- **Processing Material:** PA 30-60% Glass Filled, PVC 40% CaCO₃, CPVC, MIM, Ceramics etc...

The Problem

Injection molding and extrusion feedscrews and barrels provide their optimum efficiency when they are new. As these components wear this efficiency decreases dramatically. Machine adjustments to counteract this loss of efficiency only introduces new problems such as high shear rates, thermal degradation of polymers, greater cooling demands, inconsistent part weight/quality, etc. In addition these adjustments usually accelerate the wear condition. Many factors determine the best time to repair or replace a feedscrew/barrel but most processors continue operating well past this point. The result is excessive scrap and downtime costing you money.

Solution

CarbideX Surface Coatings

CarbideX is a specifically formulated blend of Tungsten Carbide in a Nickel or Cobalt Matrix engineered to resist wear. Feedscrews coated with CarbideX maintain their like-new condition for much longer (guaranteed at least 2X). Enhanced feedscrews prevent the negative effects of system wear: higher melt temperatures, longer plasticizing times and higher energy usage. Like-new feedscrews provide reliable, consistent production.

- 2-3X more wear resistant than standard bi-metallic feedscrews
- High percentage tungsten carbide (88%) for superior abrasion resistance
- Density > 99% equals high corrosion resistance
- 2-4 Ra µm mirror finish = low friction, easy cleaning



CarbideX Coated Feedscrew with Mirror Finish



- A: Is a standard powder metal feedscrew after 6 months processing highly abrasive ceramic filled polymer.
- B: Is a CarbideX C9000 coated feedscrew after 12 months in the same process with more life remaining.

Results

- Longer tool life and production consistency equals more profit
- Tight tolerance of screw and barrel relationship maintained
- Cost per kilogram/hour decreases
- Reliable processing consistency, less scrap and downtime
- 2 to 4 times more production
- Potential for increased barrel life
- Predictive versus reactive maintenance efforts

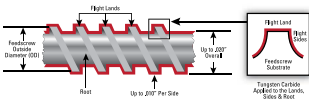

Superior Performance for Screws and Rotors Coated with CARBIDE[®]X CPR Better than Hard Chrome Plating (HCP)

- **Industry:** Plastic & Rubber
- **Application:** Single & Twin Feedscrews, Mixing Rotors & Housings processing PVC, CPVC and other Chlorinated Vinyls
- **Manufacturing:** Pipe, Window Profiles, fittings, etc...

The Problem

Injection molding or extruding PVC and CPVC polymers has its challenges due to the harmful fumes created during processing. The fumes are corrosive and permeate the micro cracks and pores in Hard Chrome Plating (HCP) resulting in damage to the feed screw. In the past, HCP was the primary option for PVC and CPVC. However, due to the corrosive nature of these polymers, HCP does not provide adequate protection of the base material, ultimately leading to **premature wear, excessive scrap and downtime.**

Solution

Application of our Chrome Plating Replacement (CPR)

CarbideX CPR is a specifically formulated blend of Carbon and Chromium in a Nickel Matrix engineered to replace HCP in PVC and CPVC Applications.

- It is applied 2-3 Times thicker (.003"/.004" per side or 0.8 - 1.1 mm per side) and more uniform than standard HCP
- Full encapsulation of the entire working surface of the feedscrew including the root, radius, flights sides, O.D. and mixers
- Eliminates the need for conforming anodes
- Highly Polished to a <4 Ra µi mirror finish for less coefficient of restitution (COR)
- Super Low porosity coating protects the substrate from chloride fumes.

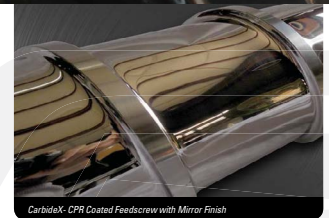
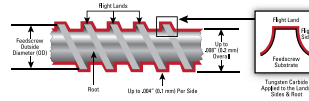

CarbideX CPR Coated Feedscrew with Mirror Finish

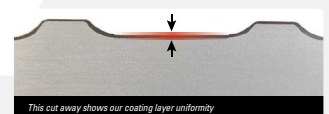

This cut away shows our coating layer uniformity

Results

Increased service life and improved performance output & uptime!

- More Corrosion Resistant than HCP
- No premature wear in specific areas that traditional hard chrome plating does; due to its lack of uniformity or thickness.
- 3-5 times longer service life
- Easier cleaning and color changes
- Can be recoated multiple times (extend asset life)
- More environmentally safe (HCP is Carcinogenic)
- Improved barrel life



Engineered Surfaces



Engineered Surfaces